

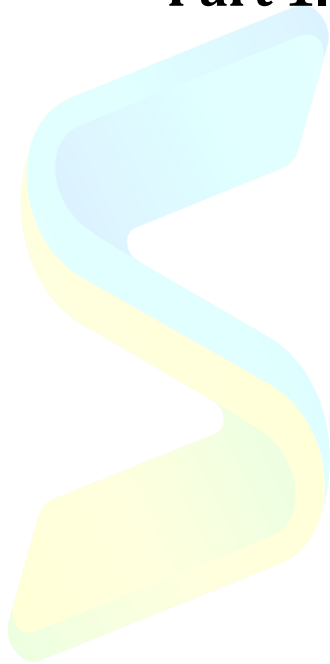

Installation of PV systems in buildings

Part 1. Components of PV system

- Reading material -



EETheSkills
VISIBLE | VALIDATED | VALUABLE



DISCLAIMER

The information, documentation and figures in this deliverable are written by the SEetheSkills project consortium under EC grant agreement 101033743 and do not necessarily reflect the views of the European Commission. The European Commission is not liable for any use that may be made of the information contained herein.

All intellectual property rights are owned by SEetheSkills consortium members and are protected by the applicable laws. Reproduction is not authorized without prior written agreement.

The commercial use of any information contained in this document may require a license from the owner of that information.

ACKNOWLEDGEMENT

This document is a deliverable of SEetheSkills project. This project has received funding from the European Union's Horizon 2020 research and innovation programme under grant agreement N° 101033743.





Part 1. Components of PV system

The sun delivers its energy to us in two main forms: heat and light. There are two main types of solar power systems, namely, solar thermal systems that trap heat to warm up water, and solar PV systems that convert sunlight directly into electricity. When the PV modules are exposed to sunlight, they generate direct current ("DC") electricity. An inverter then converts the DC into alternating current ("AC") electricity, so that it can feed into one of the building's AC distribution boards ("ACDB") without affecting the quality of power supply.

Slide 2:

Electrical model of PV cell. Now we will look into the electrical model of an ideal PV cell, and a real PV cell.

The electrical model of a PV cell represents this conversion of light into electricity by incorporating the relevant electrical parameters, such as the current generated by the cell, the voltage across the cell, and the internal resistance of the cell.

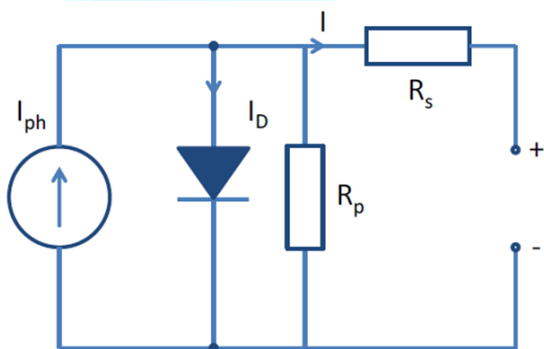

Figure 1 Ideal PV cell

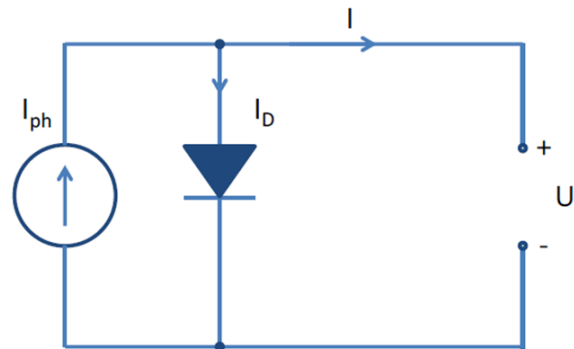

Figure 2 Real PV cell

Slide 3

The electric model of ideal PV cell contains:

- A current source, representing the current generated by the cell in response to the incident light
- A diode, representing the behavior of the cell as a p-n junction device. It allows current to flow only in one direction, which simulates the unidirectional flow of current through the PV cell.

The current I is flowing thru the conductors and on the end voltage U is generated.

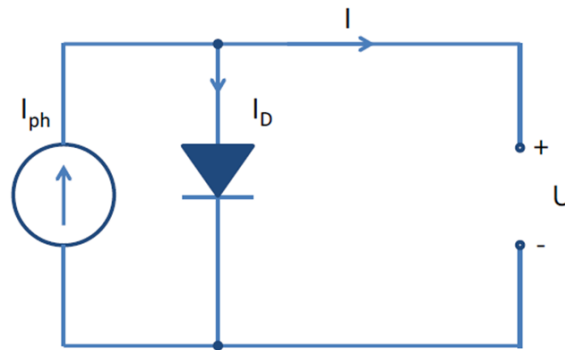

Figure 3

Slide 4

The electric model of real PV cell contains: Current generator I_{ph} , Diode I_D , Serial resistor R_s , Parallel resistor R_p .

The electrical model of a real PV cell consists of 4 elements: a current source which represents the PV current $-I_{ph}$, a diode which represents the energy level threshold for photons to trigger significant production and circulation of electron-hole pairs through the junction and two resistors. The parallel resistor R_p represents the leakage currents along the edges of the cell and the serial resistor R_s represents the losses (metal–semiconductor contact resistance, the ohmic resistance of the contacts, and the ohmic resistance of the semiconductor material).

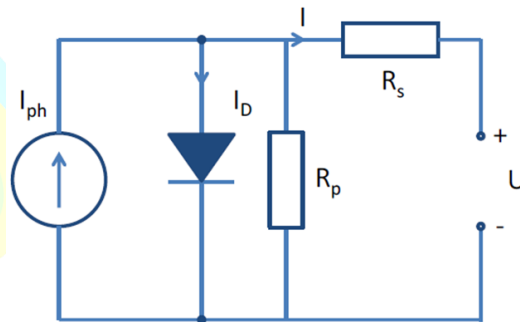

Figure 4

The current I is flowing thru the conductors and on the end of a voltage U is generated, while some losses are given thru the resistors R_s and R_p

Slide 5

PV cell.

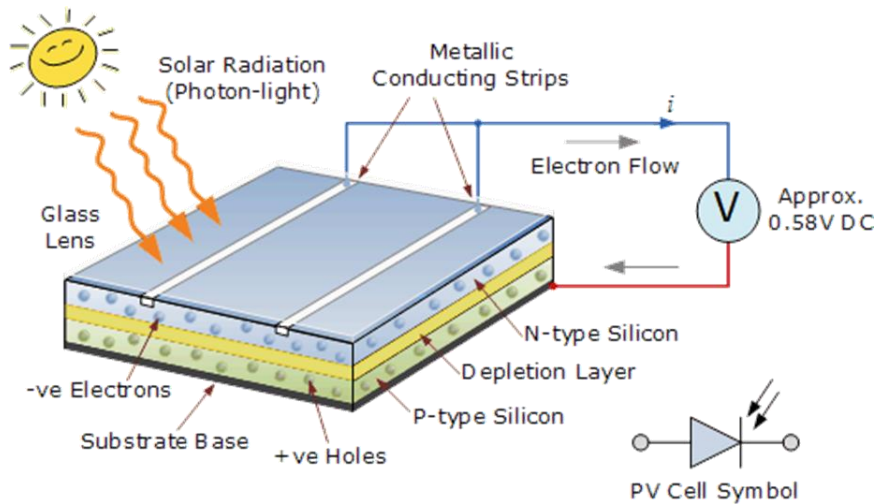

Figure 5 Harvesting the Sun's Energy: How Photovoltaic (PV) Cells Convert Sunlight into Electricity

One thing that is needed for the PV cell to work is the solar radiation or photon light. The light is falling on the surface of the PV cell - on the glass lens. On the other side of the PV cell is the substrate base. The core of the PV cell contains P-type silicon, Depletion Layer, and N-type silicon. There are the electrons and holes in the corresponding silicon layers. When light falls to the surface of the PV cell, an electron flow or current starts to flow through the metallic conducting strips and a voltage is produced on the end of the conductors.

On the end this is the electric symbol for PV cell.

Slide 6

UI diagram and Maximal Power Point

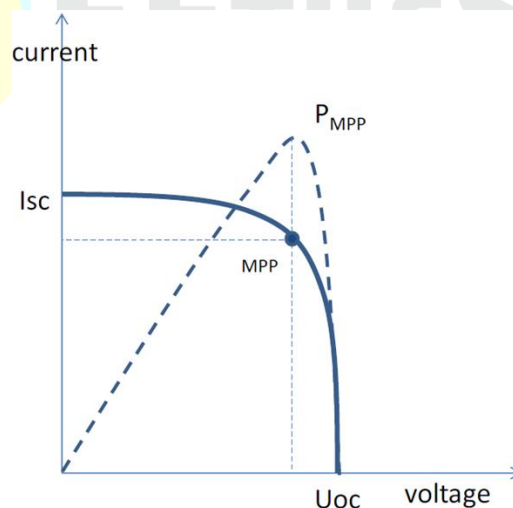

Figure 6

The UI diagram is representing the curve of the dependence between current I and voltage U . Current I is shown on the y axis and the voltage U is shown on the x axis. I_{sc} is the short circuit current when $U=0$ and U_{oc} is the open circuit voltage when $I=0$.



The dotted line represents the power generated of the PV cell. The MPP or Maximum power point is the point where the power of the PV cell reaches its maximum. P_{MPP} is the power at Maximum power point.

Slide7

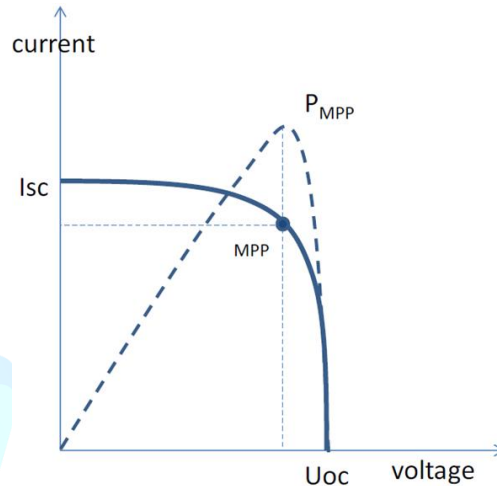

Figure 7

Power P equals to current I multiplied by voltage U . Also the power at the maximum power point equals to the current at the maximum power point I_{mpp} times the Voltage at the maximum power point U_{mpp} .

The Fill Factor FF is the available power at MPP divided by the short circuit current I_{sc} and the open circuit voltage U_{oc}

The Fill Factor FF is a measure of quality of a solar cell and always tends to have a value of 1

Slide 8

Working principal of PV system

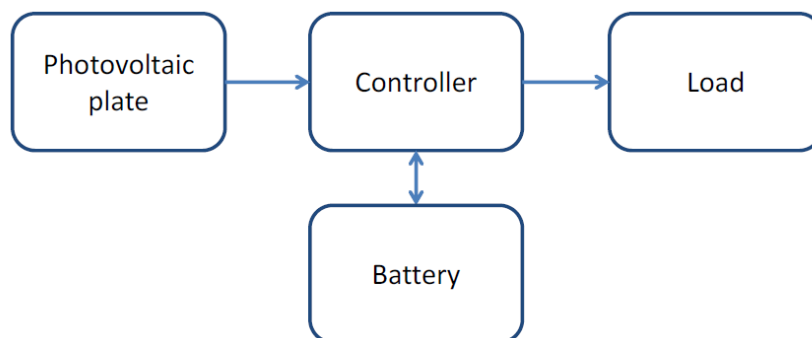

Figure 8

Every PV system is composed of the following components. The first component is a photovoltaic plate of module. Then there is the controller that controls the production and storage of electricity in the battery. And on the end there is the load.



Slide 9

Off-grid PV system

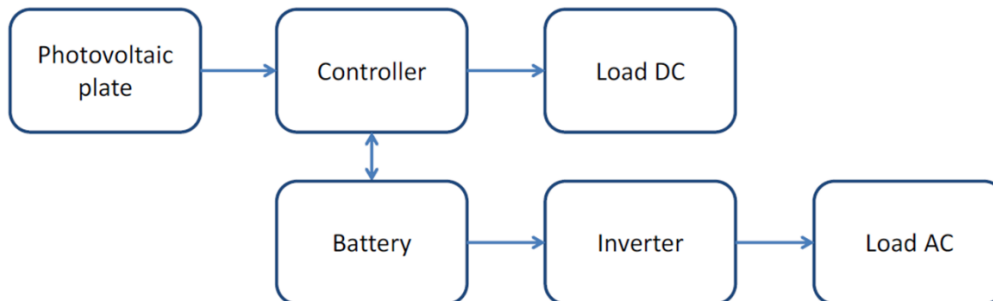

Figure 9

The Off-grid PV system is composed of the following components. The first component is a photovoltaic plate of module. Then there is the controller that controls the production and storage of electricity in the battery. From the controller there are the DC loads in the system. Also there is the inverter that converts the DC to AC to be used for the AC loads in the Off-grid PV system.

Slide 10

On-grid PV system

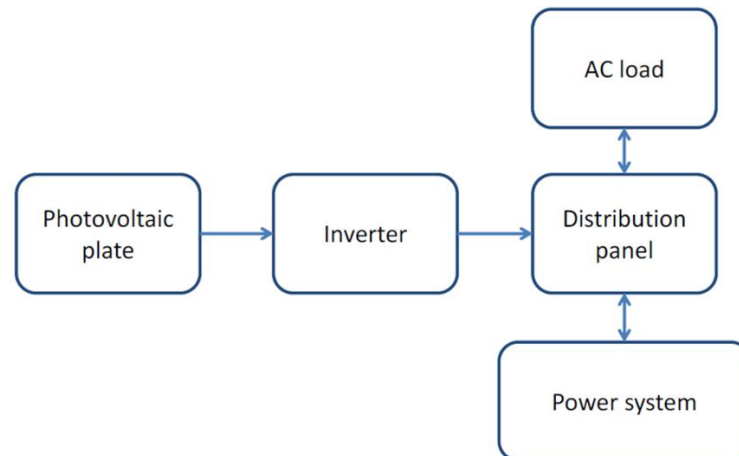

Figure 10

The On-grid PV system is composed of the following components. The first component is a photovoltaic plate of module. Then there is the inverter that converts the DC to AC and that is connected to the distribution panel in the building from where the AC loads are powered. The excess of electricity produced can be feed in to the distribution power system or it can be sold for money. When there isn't any generation of power from the PV system the loads can be powered through the distribution power system.

Slide 11

PV modules



PV module is a collection of PV cells connected in series and in parallel in order to increase the efficiency of the photovoltaic cells.

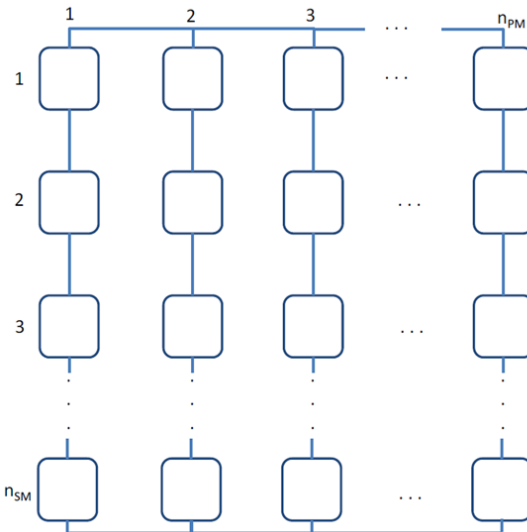

Figure 11

Typical PV module contains 36, 48 or 72 PV cells depending on the power needed.

Slide 12

The UI diagrams for the serial and parallel connections of the PV cells are shown on the figures
Connecting PV cells in a series leads to increasing the voltage, while parallel connection of PV cells leads to higher current. In both scenarios, there is an increase in the generated power, but the maximum power point is reached at different short currents and open circuit voltages.

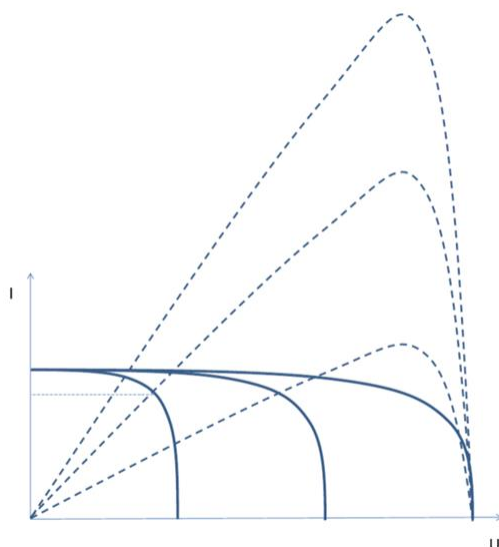

Figure 12

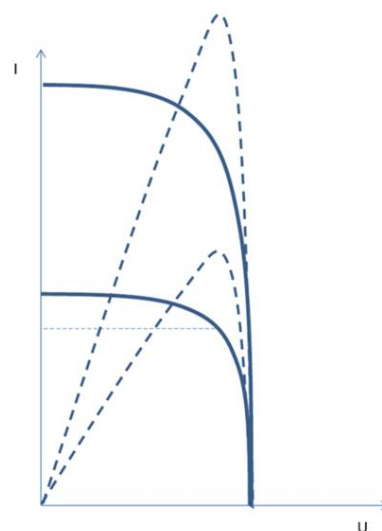

Figure 13



Slide 13

The serial connection of PV cells is summing up the voltage of every PV cell, while the current is constant

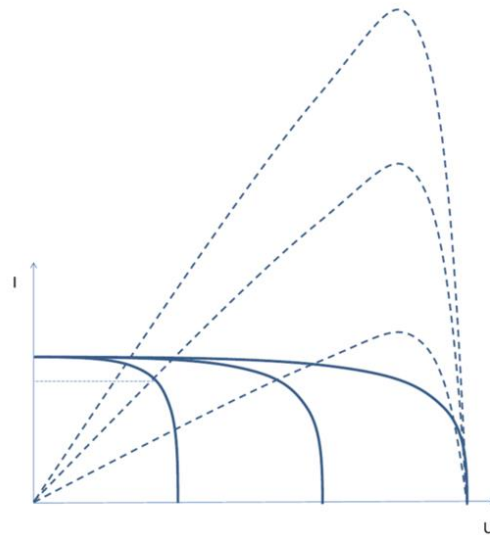

Figure 14

Slide 14

The parallel connection of PV cells is summing up the currents of every PV cell, while the voltage is constant.

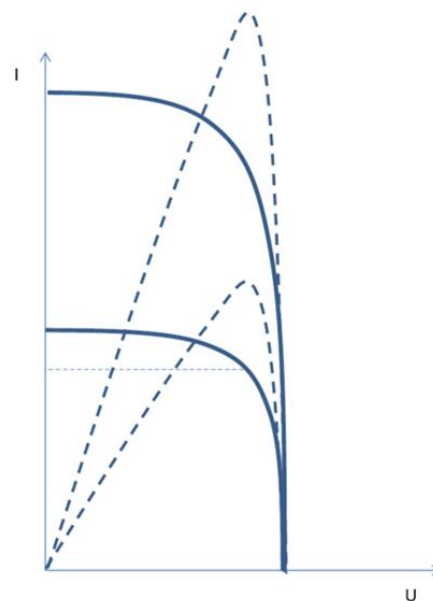

Figure 15



Slide 15

Invertors

PV module produce DC current. In order to use the generated electricity for everyday life, an invertor is necessary to transform the DC current into AC current. Invertors can be single phase or three phase depending on the needs of the PV system.

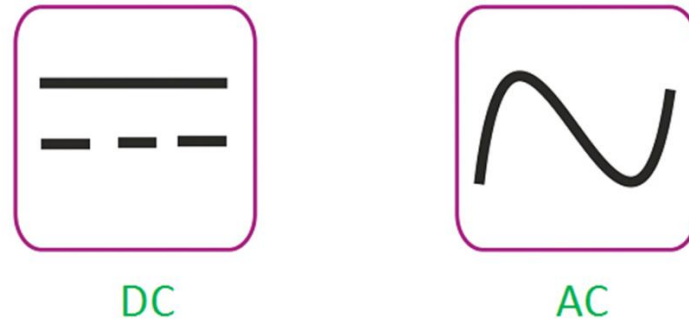

Figure 16

Slide 16

Types of invertors

There are 3 types of invertors: Central invertors, String invertors and Micro invertors.

Slide 17

Central invertor

The PV system with central invertor is composed of all the PV modules and one invertor connected to the power grid. In PV systems with central invertors only one invertor is used for the whole system.

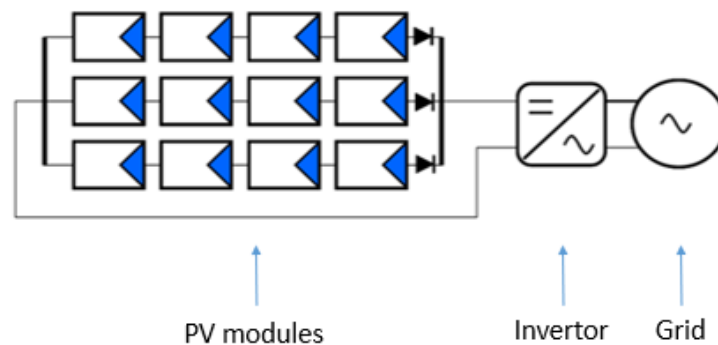

Figure 17



Slide 18

String inverter

The PV system with string inverter is composed of PV modules and invertors connected to every string of the PV system. All the invertors are summed up and connected to the grid. In PV systems with string invertors multiple invertors are used, one on every string of the system. The number of string invertors depends of the number of strings in the system.

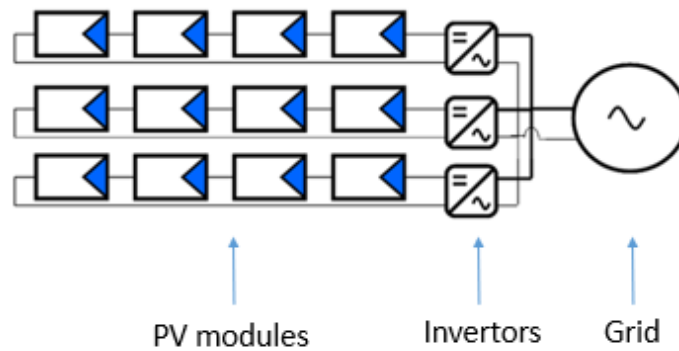

Figure 18

Slide 19

Micro inverter

The PV system with micro invertors is composed invertors connected to each PV module. In PV systems with micro invertors multiple invertors are used, one on every PV module in the system. The number of micro invertors depends of the number of PV in the system.

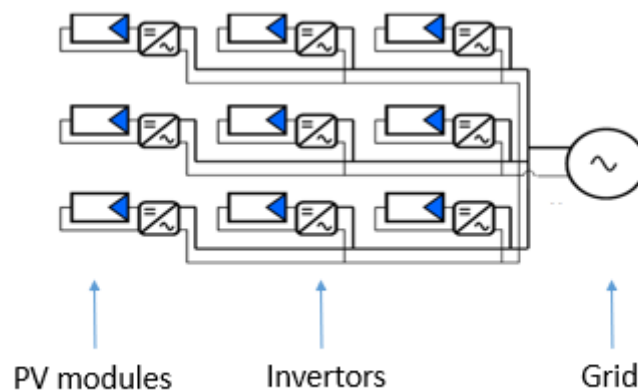

Figure 19



Slide 20

The Advantages of micro invertors are: greater efficiency and increased reliability of the PV system. The disadvantages of the micro invertors are that they are more expensive and more difficult to install than other types.

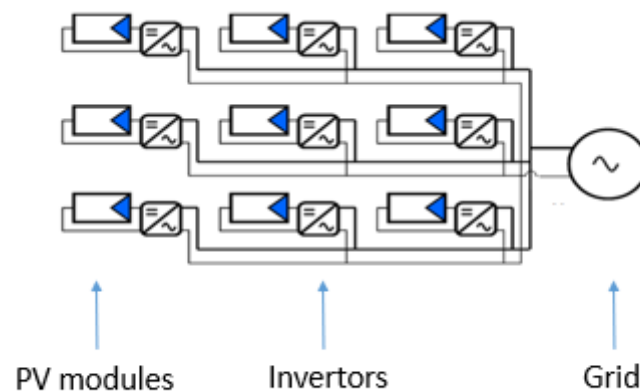
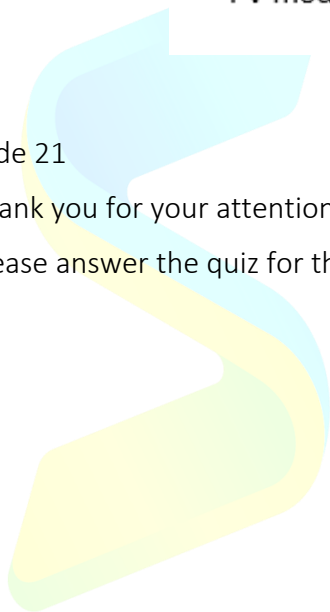

Figure 20

Slide 21

Thank you for your attention

Please answer the quiz for this part before proceeding to the next one



EETheSkills
VISIBLE | VALIDATED | VALUABLE